

PADS No. 087/000661
Weatherproof Telephone RA711-FK

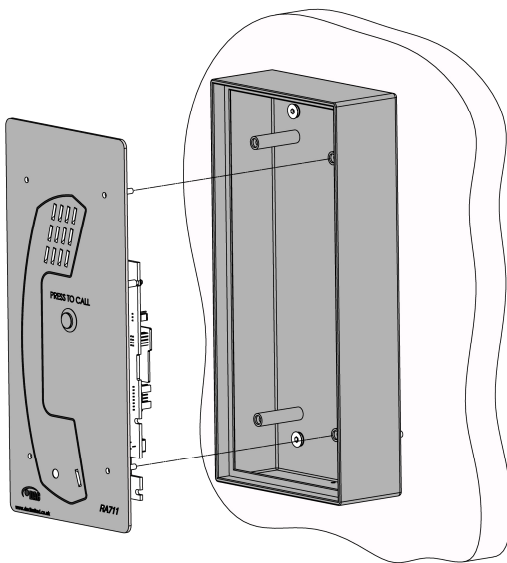

- RA711 Series
- Network Rail acceptance
- Full Keypad
- Auto Clear Down
- LED Indicator for off-hook
- Raised buttons in line with DD A directives
- All weather protection
- Simple installation
- Fast-fit terminal connection
- Various mounting options
- REN-1 rating
- Line powered
- CE compliant

Mounting options:



Wall mounting:

On Wall box available from DAC:

Part No. RA711-NR
PADS No. 087/000666

Top of pole mounting:

Top of Pole bracket available from DAC:

Part No. 503483
PADS No. 087/000667

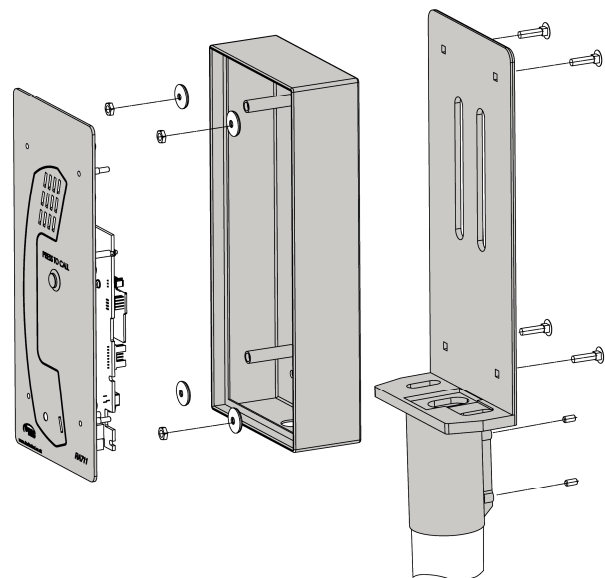

TECHNICAL SPECIFICATION

Speech/ Network Interface:

Voice switched (VOX) semi duplex operation.

Ringling:

Through internal speaker, REN 1,

Power Supply:

Line powered, 15mA min.

Call Cleardown/Time out:

Adjustable timer from 1 to 10 minutes or off.
Auto cleardown function on tone detection from the line

Temperature:

Operating: -30° C to +60° C
Storing: -40° C to +70° C

Relative Humidity:

Up to 95% (non-condensing)

Keypad/Buttons:

Heavy duty metal keypad and buttons, Vandal resistant.

Material:

Robust high grade Stainless Steel

Programming:

Using on board keypad and externally connected security keypad

Weight:

1.8kg

Safety:

Manufactured to BS EN 60950

Protection:

Dust and Liquids to BS 5490: 1977 IP55

